

Rev.	Description	Date
01	Release for production	08/07/2012

Note: Label part with sticker or as following 350015-01-RA-Vxxxx where xxxx is the vendor number listed on customer order

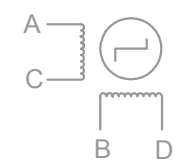
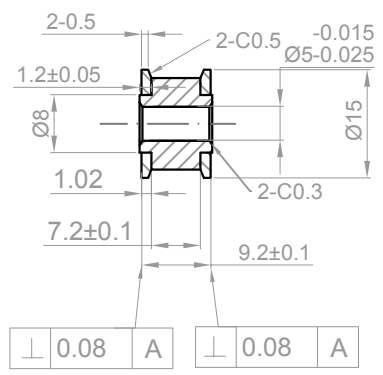
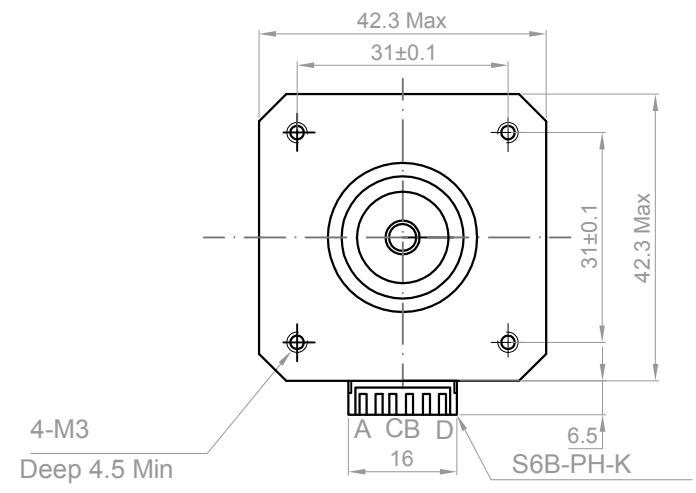
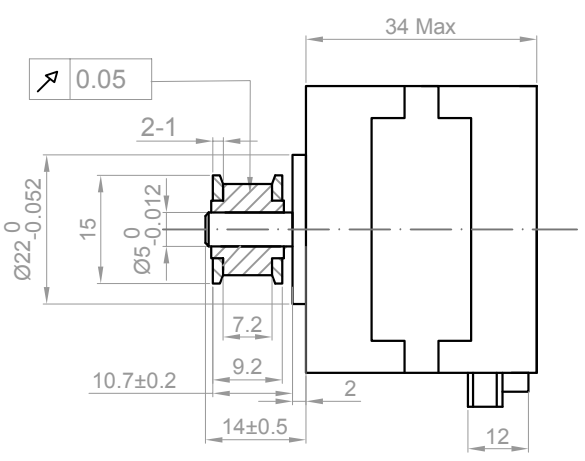

Note:  
 1. Without burr on end face, polish tooth surface.  
 2. The tolerance unmarked follows GB/T1804-m.  
 3. The tolerance of concentricity is 0.05mm.  
 4. Add Loctite 648 and glue injection groove between pulley and shaft.

NO.	Item	Specification
1	Gear Form	MXL
2	Number of Teeth	20
3	Pitch	2.032
4	Pitch Diameter	12.94
5	External Diameter	12.43
6	Material	Aluminium Alloy YL12

NO.	Item	Specification	NO.	Item	Specification
1	Step Angle	1.8°	7	Insulation Class	Class B
2	Rated Voltage	12 V	8	Rotor Inertia	38 g.cm <sup>2</sup>
3	Rated Current	0.4 A	9	Detent Torque	12mN.m
4	Resistance Per Phase	30 Ω ±10%	10	Holding Torque	260mN.m
5	Inductance Per Phase	37 mH ±20%	11	Insultion Resistance	100MΩmin(500DC)
6	Number of Phase	2			

Drawn	Rainia	08/07/2012	<b>Kysan Electronics</b> www.kysanelectronics.com		
Checked	Sara	08/07/2012			
Eng Appr.					
Mfg Appr.					
Q.A.			Email : info@kysanelectronics.com		
SKU	<b>1040074</b>		Size : A4	Weight(Kg): 0.2	Unit: mm
			Scale: 2:1		Sheet 1 of 1