

Rev.	Description	Date
01	Release for Production	08/04/2015

Direction of Rotation

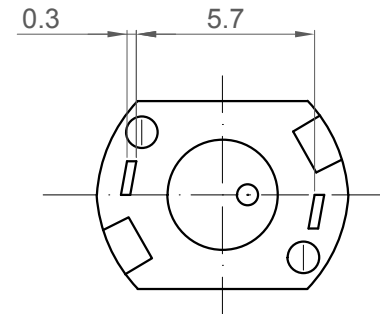
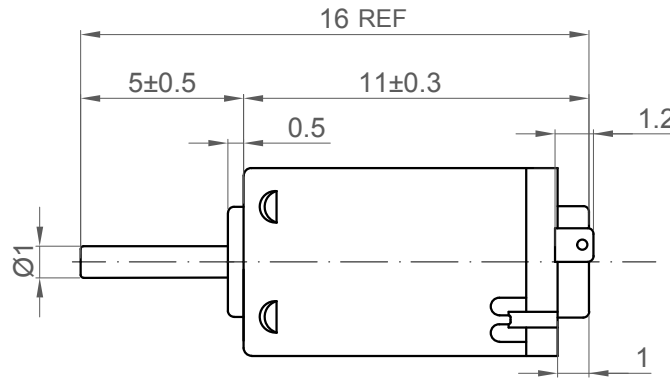
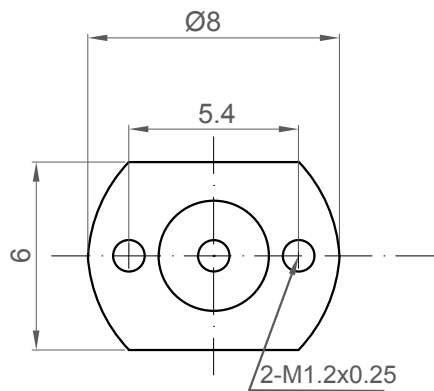

NO.	Item	Specification	NO.	Item	Specification
1	Rated Voltage	3.0 VDC	7	Output	0.1 W
2	No Load Speed	11800 RPM±10%	8	Stall Torque	2.8 g.cm
3	No Load Current	0.04 A Max	9	Stall Current	0.16 A
4	Rated Torque	1.5 g.cm			
5	Rated Current	≤0.1 A			
6	Rated Speed	5800 RPM±10%			

Drawn	Feny	08/01/2012
Checked	Stephany	08/04/2015
Eng Appr.		
Mfg Appr.		
Q.A.		
SKU	1112352	

Kysan Electronics

www.kysanelectronics.com

Size A4	Weight(Kg):	Unit: mm
Scale: 4:1		Sheet1 of 1