

Rev.	Description	Date
01	Update	04/24/2012

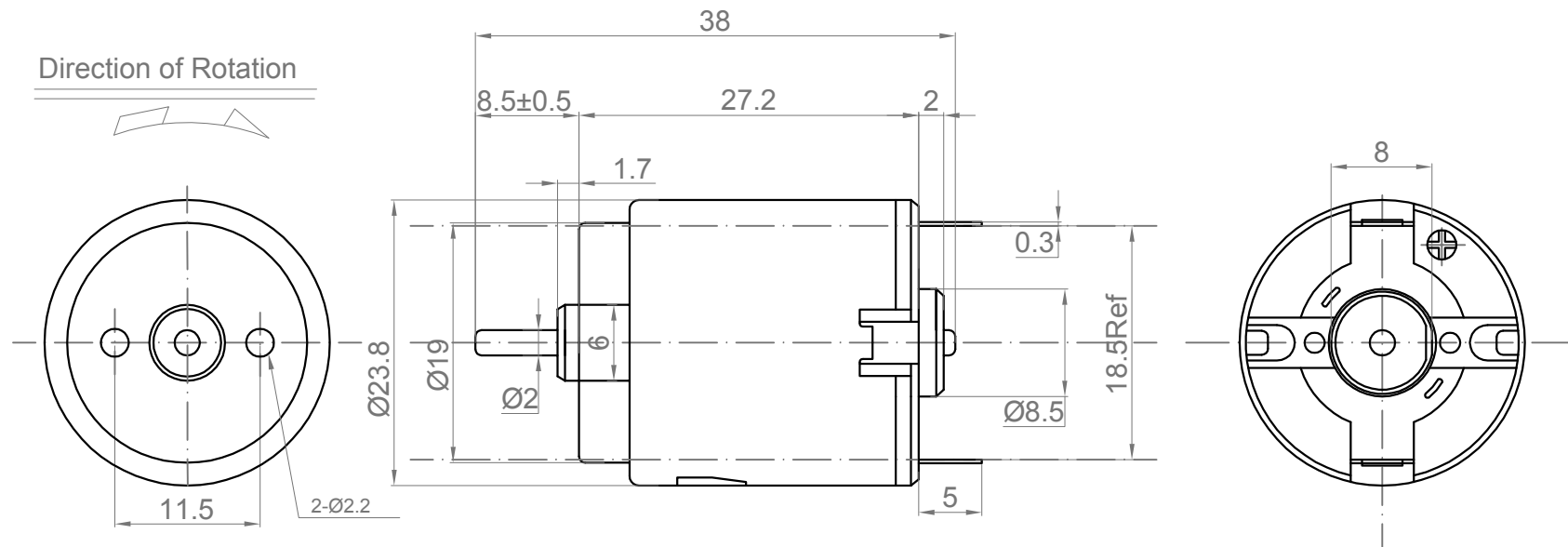

NO.	Item	Specification	NO.	Item	Specification
1	Rated Voltage	3 V DC	7	Rated Current	0.56A MAX
2	Operation Voltage Range	3-6 V/DC	8	Rated Speed	5450±10% RPM
3	Rated Load	8.86 g.cm	9	Stall Torque	42 g.cm
4	Direction of Rotation	CW	10	Stall Current	1.4A
5	No Load Current	0.15A MAX			
6	No Load Speed	6900±10% RPM			

Drawn	L	03/04/2016	<b>Unit: mm</b>  <b>Kysan Electronics</b> <a href="http://www.kysanelectronics.com">www.kysanelectronics.com</a> <a href="mailto:info@kysanelectronics.com">info@kysanelectronics.com</a>	
Checked				
Eng Appr.				
Mfg Appr.				
Q.A.				
SKU	1112378		Size A4	Weight(Kg):
			Scale: 4:1	