

Rev.	Description	Date
1	RELEASE FOR PRODUCTION	9/29/2015

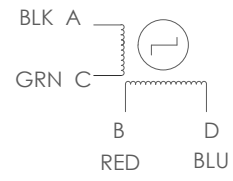
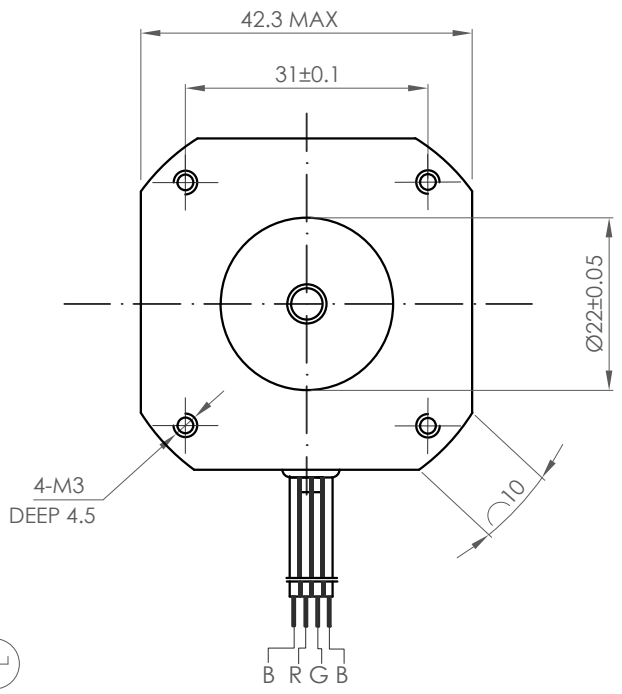
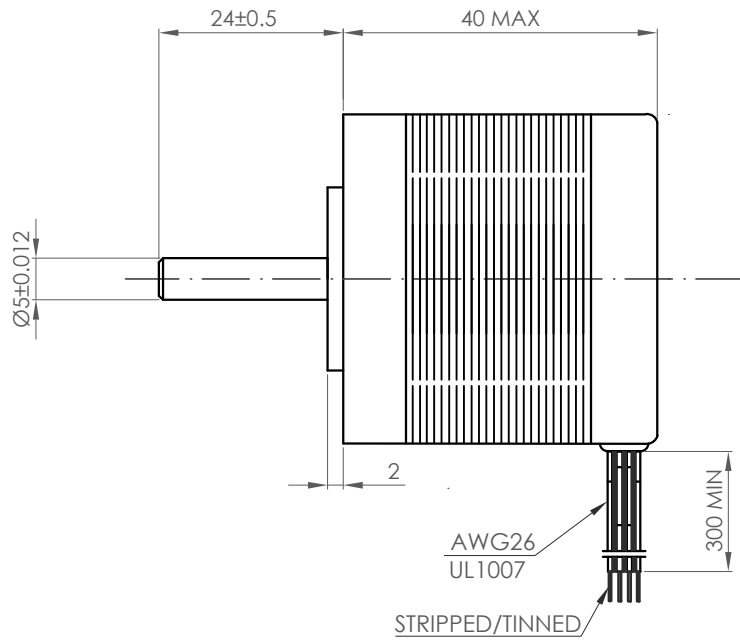

NO.	Item	Specification	NO.	Item	Specification
1	Step Angle	1.8° ±5%	7	Insulation Class	Class B (130°C)
2	Rated Voltage	3.4 V	8	Holding Torque	4.0 kg.cm
3	Rated Current	1.7 A	9	Insulation Resistance	100 MΩ(500 VDC)
4	Resistance Per Phase	2.0 Ω±10% Ω	10	Rotor Inertia	54 g.cm <sup>2</sup>
5	Inductance Per Phase	3.0 mH±20% mH	11	Defent Torque	220 g.cm
6	Number of Phase	2	12	Number of Lead Wires	4

UNLESS OTHERWISE SPECIFIED:		NAME	DATE
TOLERANCES: (MILLIMETERS)	UPDATED	STEPHANY	9/29/2015
FRACTIONAL: ±			
ANGULAR: ±			
TWO PLACE DECIMAL: ±	ENGR APPR.		
THREE PLACE DECIMAL: ±	MFG APPR.		
FOUR PLACE DECIMAL: ±			
COMMENTS:			

UNIT: MILLIMETERS			
<b>KYSAN ELECTRONICS</b>			
WWW.KYSANELECTRONICS.COM			
SIZE	SKU	REV	
LETTER	1124041	01	
SCALE: 1:1	WEIGHT (KG): 0.24	SHEET 1 OF 1	