

NO.	ITEM	SPECIFICATION
1	Step Angle	1.8° ± 5%
2	Rated Voltage	3.4 V
3	Current Per Phase	1.7 A
4	Resistance Per Phase	2 Ω ± 10%
5	Inductance Per Phase	3mH ± 20%
6	Number of Phase	2
7	Insulation Class	Class B
8	Rotor Inertia	54 g.cm <sup>2</sup>
9	Holding Torque	3.4 Kg.cm Min
10	Detent Torque	220 g.cm Max

Rev.	Revision	Date
01	Update	12/1/2011

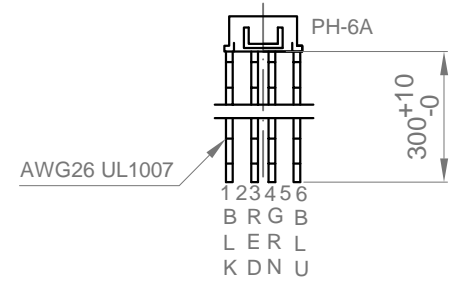
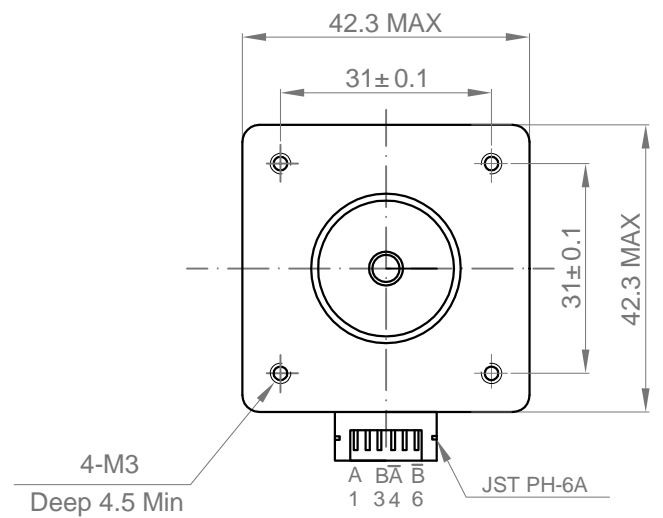
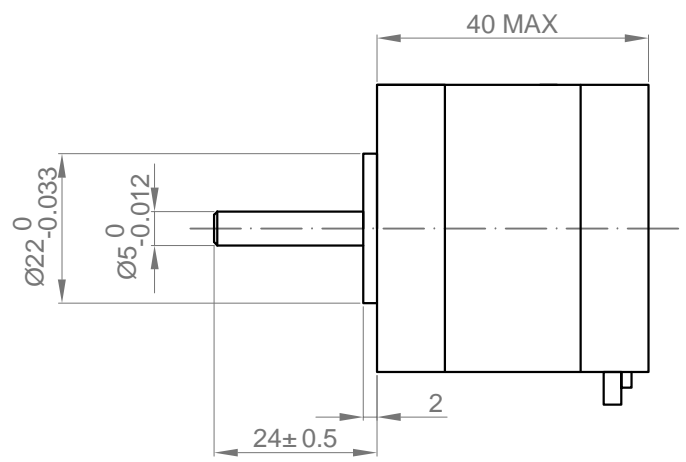

DRAWN	Emily	12/1/2011
CHECKED	Sara	12/1/2011
ENG APPR.		
MFG APPR.		
Q.A.		

UNIT: mm		
Kysan Electronics		
SKU 1124079	SIZE A4	Email Info@kysanelectronics.com
SCALE: 2:1	Weight(kg): 0.34	REV 01
		SHEET 1 OF 1