

# 混合式步进电机规格书

## HYBRID STEPPING MOTOR SPECIFICATION

外形图 (DIMENSIONS) unit=mm

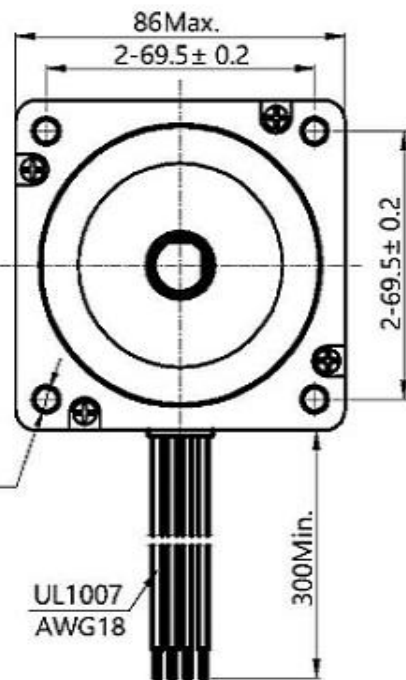
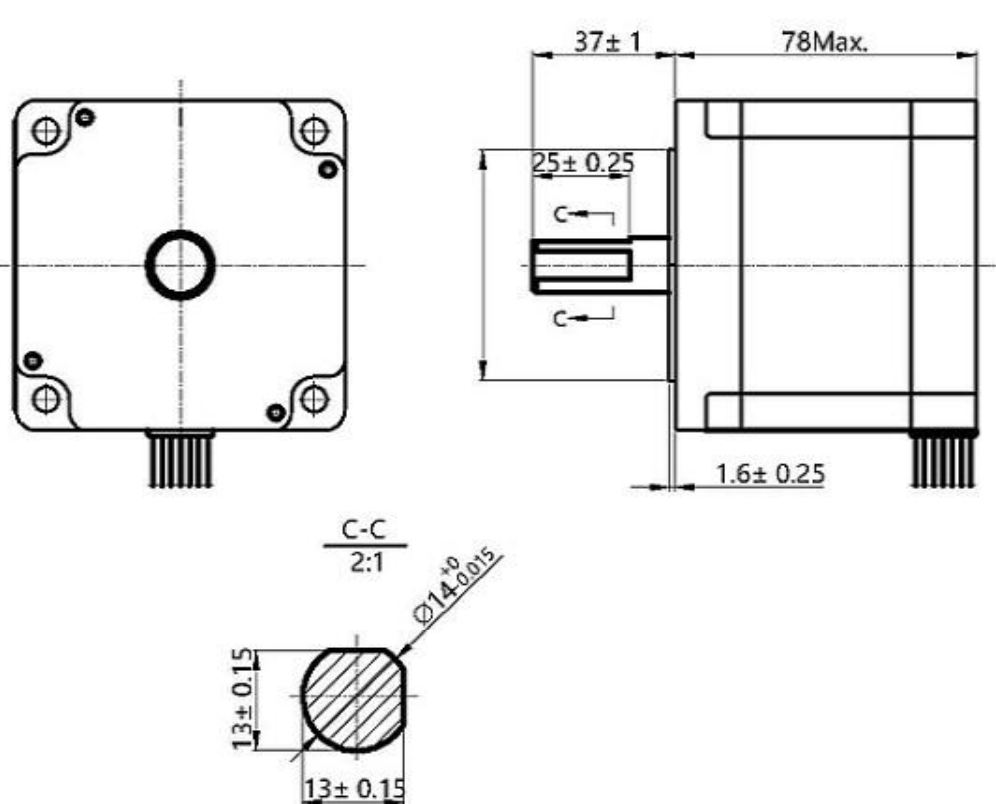

电气原理图

Wiring Diagram

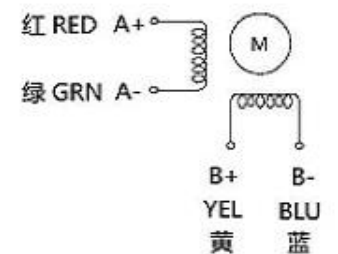

励磁顺序vs.旋转方向

Exciting Sequence vs. Direction of Rotation

STEP	A+	B+	A-	B-	
1	+	+	-	-	<div style="display: flex; align-items: center;"> <div style="margin-right: 10px;">↓</div> <div style="text-align: center;"> <p>CW</p> <p>↑</p> </div> <div style="margin-left: 10px;"> <p>↑</p> <p>CCW</p> </div> </div>
2	-	+	+	-	
3	-	-	+	+	
4	+	-	-	+	

从安装面看为顺时针方向  
Clockwise view from mounting side

1、相数 Number of Phase	2
2、步距角 Step Angle	1.8° deg.
3、相电压 Phase Voltage	1.6 V
4、相电流 Phase Current	4.5 A
5、相电阻 Phase Resistance	0.35 Ω ± 0.1(20°C)
6、相电感 Phase Inductance	2.5 mH ± 20%(1kHz 1V RMS)
7、保持力矩 Holding Torque	4 N.m
8、绝缘等级 Insulation Class	B (130°) 温升 80K Max.
9、重量 Weight	2.3 kg

规格 Specifications

备注 Comment

版本 REV.	变更内容 REVISION RECORD	日期 DATE
设计 DESIGN		
标准化 STANDARD		
工艺 TECHNOLOGY		
审核 CHECK		
批准 APPROVE		

规格书  
Specification

Kysan Electronics

SKU	1127003				
材料 MATERIAL	变更标识 ECN SIGN	※	SIZE	A4	
版本 REV.	A	比例 SCALE	1:2	页 SHEET	1 of 1