

NO.	ITEM	SPECIFICATION
1	Rated Voltage	4.4V
2	NO. of Phase	2
3	Step Angle	1.8° ± 5%
4	Resistance Per Phase	2.9Ω ± 10%
5	Inductance Per Phase	12mH ± 20%
6	Current Per Phase	2A
7	Holding Torque	42Kg-cm
8	Insulation Class	Class B
9	Dielectric Strength	100Mohm500VDC

Rev.	Revision	Date
01	Update	2/28/2011

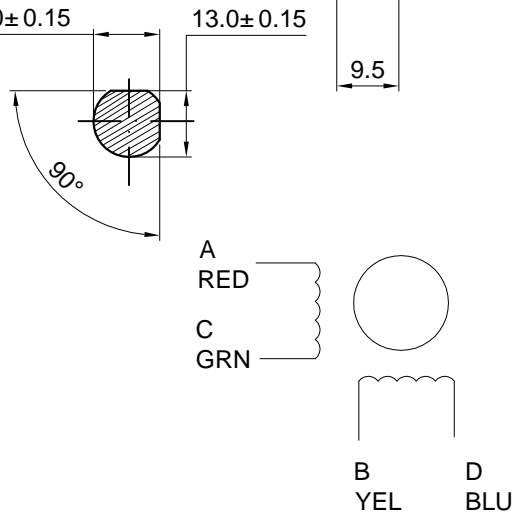
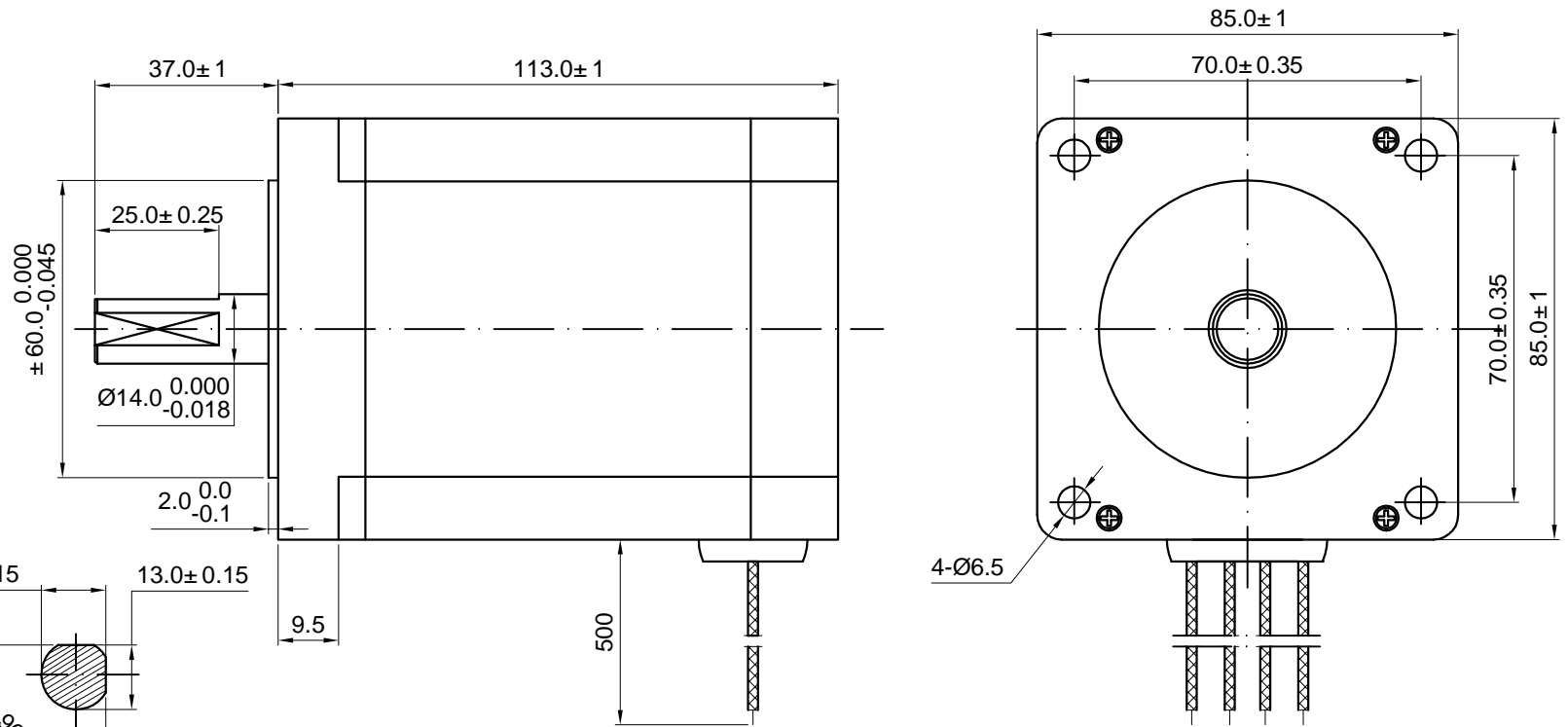

DRAWN	Alex	2/28/2011
CHECKED	Sara	2/28/2011
ENG APPR.		
MFG APPR.		
Q.A.		

UNIT: mm		
Kysan Electronics		
SIZE A4	Kysan SKU 1127004	REV 01
SCALE: 1:1	Weight(kg): 3.5	SHEET 1 OF 1

85BYGH450B-01