

Rev.	Description	Date
01	Release for Production	11/21/2012

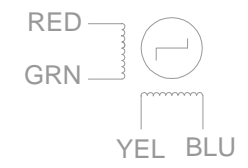
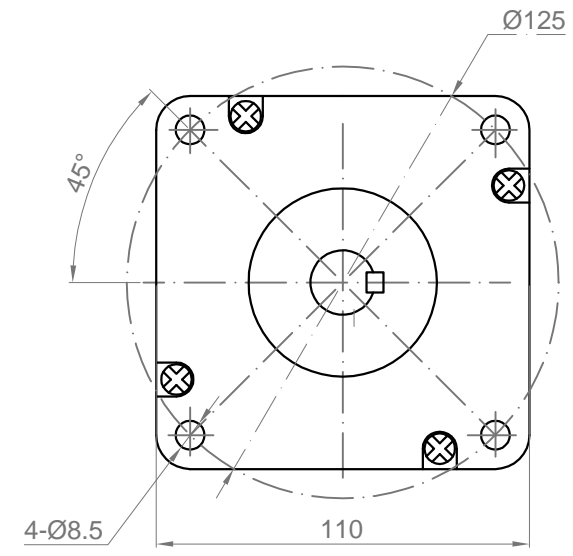
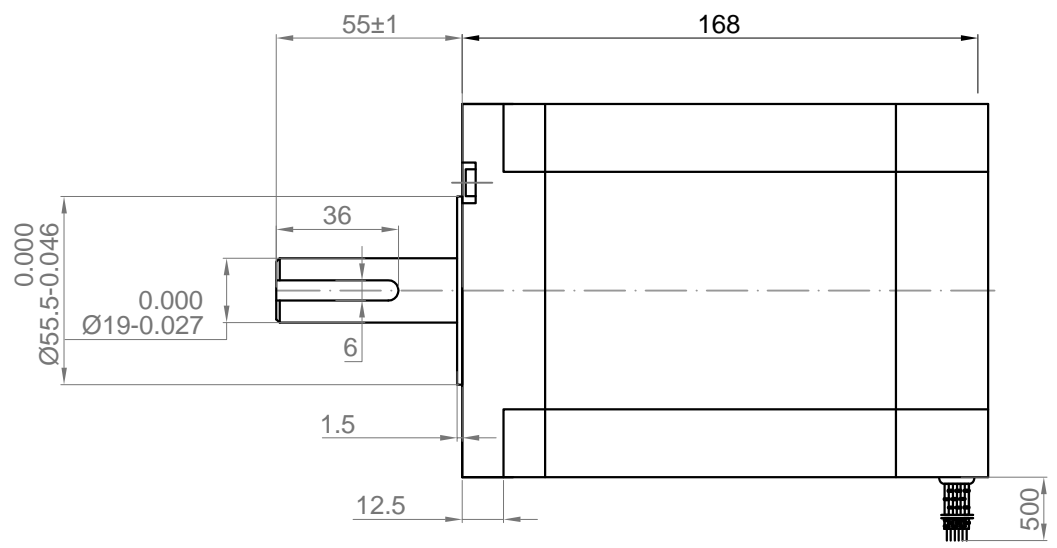

NO.	Item	Specification	NO.	Item	Specification
1	Step Angle	0.9° / 1.8°	7	Holding Torque	24 N.m
2	Voltage	220 VAC			
3	Current Per Phase	6 A			
4	Resistance Per Phase	0.9 Ω			
5	Inductance Per Phase	16 mH			
6	Number of Phase	4			

Drawn	L	04/12/2016	Kysan Electronics www.kysanelectronics.com info@kysanelectronics.com		
Checked					
Eng Appr.					
Mfg Appr.					
Q.A.					
SKU	1128001		Size : A4	Weight(Kg): 9.8	Unit: mm
			Scale: 1:1		Sheet 1of 1