

NO.	ITEM	SPECIFICATION	CONDITION
1	Rated Voltage	7 V	
2	NO. of Phase	4	
3	Step Angle	7.5°	
4	No. of Step per Revolution	48	
5	Resistance Per Phase	20 Ω± 7%	20° C
6	Inductance Per Phase	11mH± 20%	1Khz(Ref)
7	Current Per Phase	0.35 A	
8	Holding Torque	>450 g.cm	
9	Pull-in Rate	300 pps	
10	Insulation Class	Class E	
11	Pull-in Torque	150 g.cm	100pps
12	Insulation Resistance	100 MΩ min	500 VDC
13	Excitation	2-2	
14	Operation Temp Range	-10°C~+40°C	
15	Stepping Accuracy	7.5° ± 7%	
16	Detent Torque	<125 g.cm	
17	Rotor Inertia	<7.5 g.cm ²	
18	Life	3000h Min	100pps(20°C)

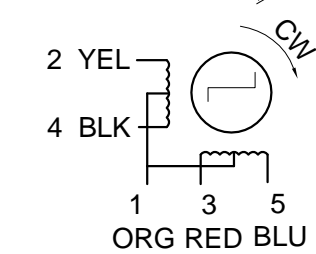
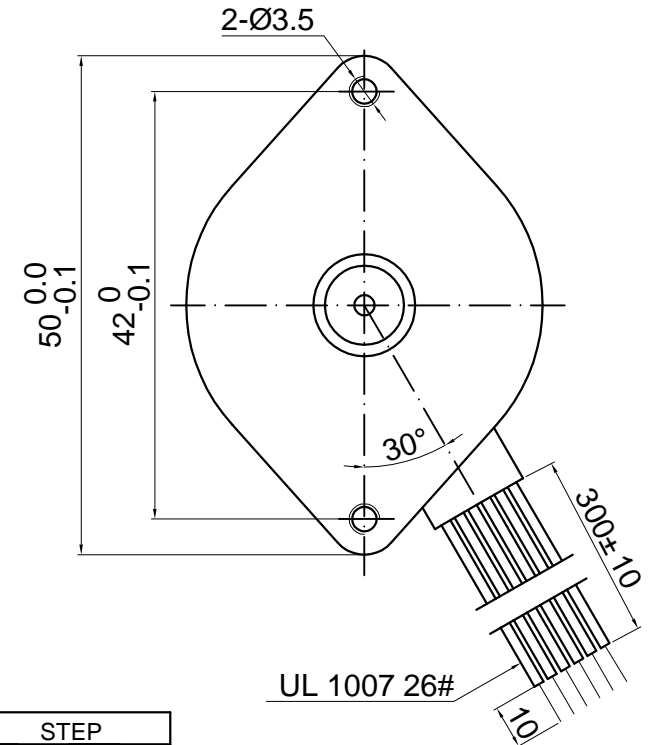
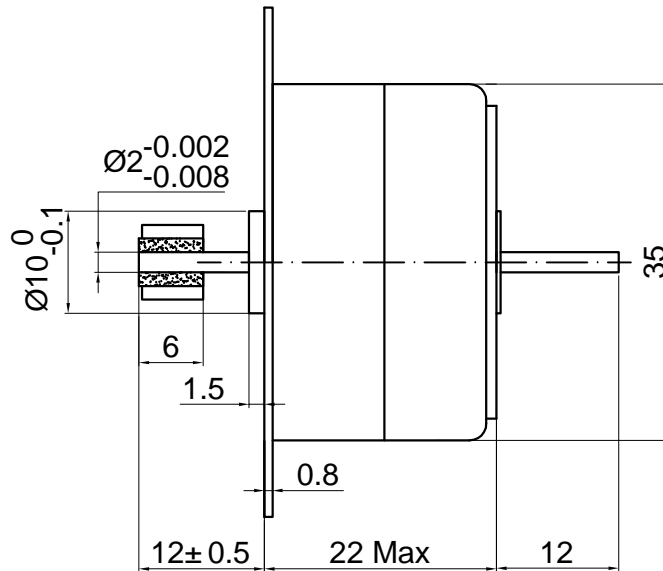

PINION SPECIFICATION	
Number of Teeth	10
Module	0.6
Pressure Angle	20 °
Pitch Dia	Ø6
Outside Dia	Ø7.2 ⁰ _{-0.05}
Accuracy	IT 7-8
Material	Powder Metallurgy

Pin NO.	WIRE COLOR	STEP			
		1	2	3	4
1	ORG	+	+	+	+
2	YEL	-	-	-	-
3	RED	-	-	-	-
4	BLK	-	-	-	-
5	BLU	-	-	-	-
6					

DRAWN	Amily	7/20/2011
CHECKED	Sara	7/20/2011
ENG APPR.		
MFG APPR.		
Q.A.		

UNIT: mm

Sinotech

35BY48L030-01

SIZE
A4

P/N
171601

REV
01

SCALE: 3:1

Weight(kg): 0.1

SHEET 1 OF 1

Rev.	Revision	Date
01	Update	7/20/2011