

8 7 6 5 4 3 2 1

D

D

Direction of Rotation

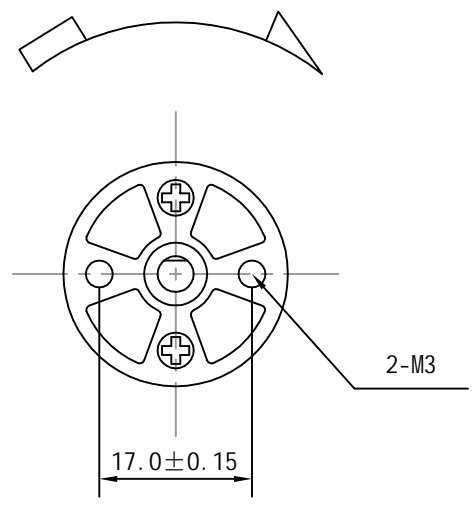
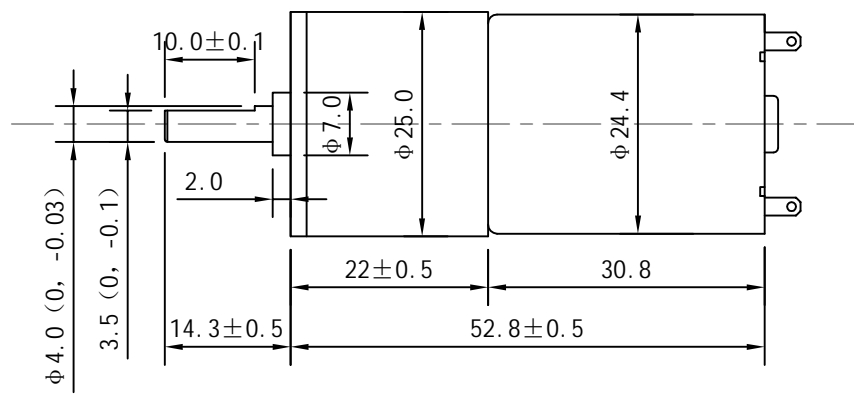

C

C

B

B

No.	Item	Specification	No.	Item	Specification
1	Rated Voltage	24V DC	7	Gear Ratio	51.5:1
2	Rated Load	100mN.m	8	Direction Of Rotation	CW
3	No Load Current	$\leq 100\text{mA}$	9		
4	No Load Speed	$160 \pm 10\%$ RPM	10		
5	Rated Load Current	$\leq 230\text{mA}$	11		
6	Rated Load Speed	$128 \pm 10\%$ RPM			

Drawn	Bruce	11/01/2023	Unit: mm	
Checked	Eva	11/01/2023		
Eng Appr.			Kysan Electronics www.kysanelectronics.com	
Mfg Appr.				
Q.A.				
SKU: 1153040			Size :A4	Weight(Kg):
			Scale :	

8 7 6 5 4 3 2 1

A

A

额定电压: 24VDC

制作日期:

转 向: CW

P_0	EF	I	N
3	100	1000	200
1.5	50	500	100
[W]	[%]	[mA]	r/min

— N: Speed: 转速

— I: Current: 电流

— P: Out power: 输出功率

— EF: Efficiency: 效率

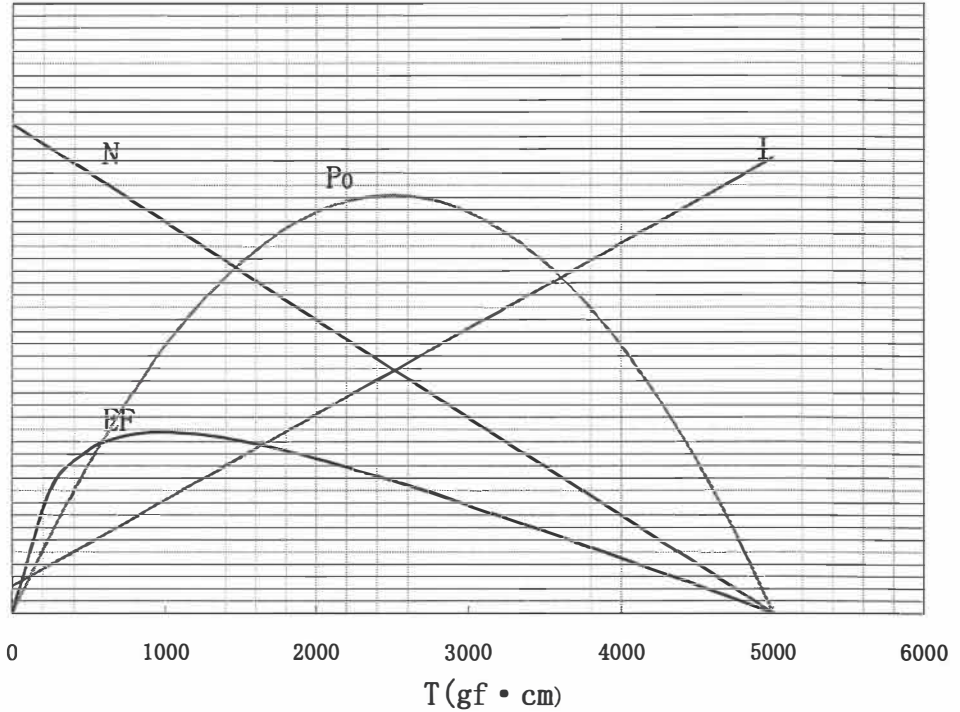

T: torque

	T (mNm)	(gf. cm)	N (r/min)	I (mA)	P_0 [W]	EF [%]
No Load... N, I (空载)	0.00	0	160.00	45	0.0	0.00
	9.80	100	156.80	59	0.2	11.36
	39.22	400	147.20	101	0.6	24.91
	68.63	700	137.60	143	1.0	28.78
Rated... T (负载)	98.04	1000	128.00	185	1.3	29.57
	127.45	1300	118.40	227	1.6	28.98
	156.86	1600	108.80	269	1.8	27.66
	186.27	1900	99.20	311	1.9	25.90
	215.69	2200	89.60	353	2.0	23.86
	245.10	2500	80.00	395	2.1	21.64
	274.51	2800	70.40	437	2.0	19.28
	303.92	3100	60.80	479	1.9	16.82
	333.33	3400	51.20	521	1.8	14.28
	362.75	3700	41.60	563	1.6	11.68
	392.16	4000	32.00	605	1.3	9.04
	421.57	4300	22.40	647	1.0	6.36
Stop... T (堵转)	490.20	5000	0.00	745	0.0	0.00
Max... P_0 (最大功率)	245.10	2500	80.00	395	2.1	21.64
Max... EF (最大效率)	96.71	986	128.43	183	1.3	29.57